

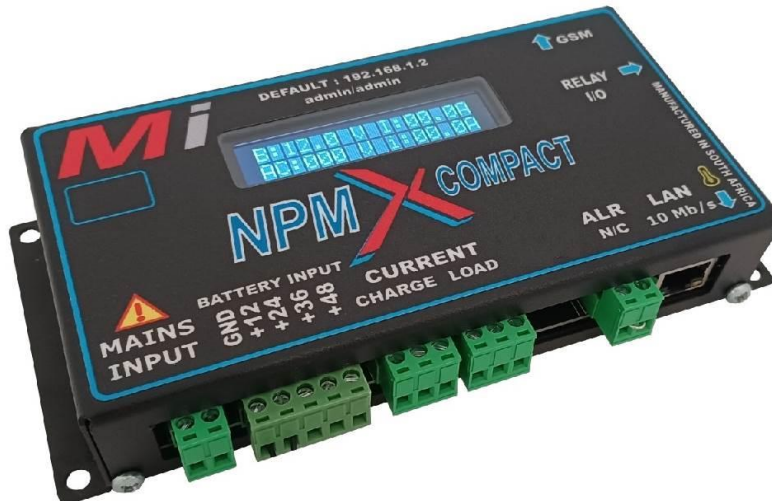

Innovative Electronics for a Changing World



***NPM X- Compact Remote Network Power Monitor with optional
GSM module and Relay module***

INDEX

1. SYSTEM DESCRIPTION ([page 1](#))
2. BATTERY WIRING FOR SEPARATE LITHIUM / LEAD ACID / GEL / AGM ([page 2](#))
3. BATTERY WIRING FOR LITHIUM BATTERIES WITH 2 WIRES ([page 5](#))
4. CURRENT SENSORS CONNECTIONS ([page 6](#))
5. ALARM INPUT WIRING ([page 7](#))
6. RELAY MODULE – **OPTIONAL** ([page 8](#))
7. GSM MODULE SETUP AND FUNCTIONS - **OPTIONAL** ([page 9](#))
8. DEFAULT IP – FACTORY RESET AND PASSWORDS ([page 10](#))
9. WEB PAGES ([page 11](#))
10. NETWORK AND GSM CONFIGURATION PAGE ([page 14](#))
11. SNMP CONFIGURATION ([page 16](#))
12. TFTP – REMOTE FIRMWARE UPGRADE VIA A NETWORK ([page 16](#))
13. OID TABLE ([page 17](#))
14. MI-SNMP MONITOR SOFTWARE ([page 18](#))
15. PHYSICAL DIMENSIONS ([page 19](#))

Network Based Remote Power Monitor

NPM X - Compact

FOR 12V,24V,36V and 48V Battery systems

1. SYSTEM DESCRIPTION

Main Unit



The NPM X-Compact (Network power monitor) was designed to assist Network specialists with Power related information via **Ethernet (SNMP)** and **GSM** Communication.

The NPM-X measures the **Total Battery** Voltage for single connected **Lithium** batteries from 12V to 48V batteries as well as the total and **separate** battery voltages of each battery for series connected lead acid or gel battery banks.

Charge Current from the clients charging source flowing to the battery and **Load** current flowing to the clients equipment is measured via non-contact 4Kv isolated DC current sensors.

Mains AC voltage level present, **Alarm** input and **temperature** is also measured.

AC Voltage is measured via the 2 way power input connector in front of the unit

All information is available via web pages, SMS(optional) and SNMP over Ethernet.

Embedded Web pages for monitoring and configuration of the system.

The unit supports the **SNMP V1** and **SNMP V2C** communication platform to be compatible with any SNMP monitoring software platforms as well with our free to download **Mi-SNMP Manager** software for Windows.

2x16 LCD display for quick indication of all power related information for onsite readings.

OPTIONAL 5 WAY RELAY MODULE

2. Battery wiring for separate Lithium / Lead acid / Gel /AGM

The wiring from – (ground) and each batteries + (positive) to the NPM-X or the wiring from a single Lithium battery can be small (thin) gauge wire as the NPM-X does not consume large currents and only sense the battery voltages from here

Current consumption in total with LAN port connected 110mA @ 12Vdc / 55mA @ 24Vdc and 30mA @ 48Vdc

12V example – Lithium or lead acid / Gel / AGM

Connect Battery – to GND terminal and Battery + to the +12V terminal

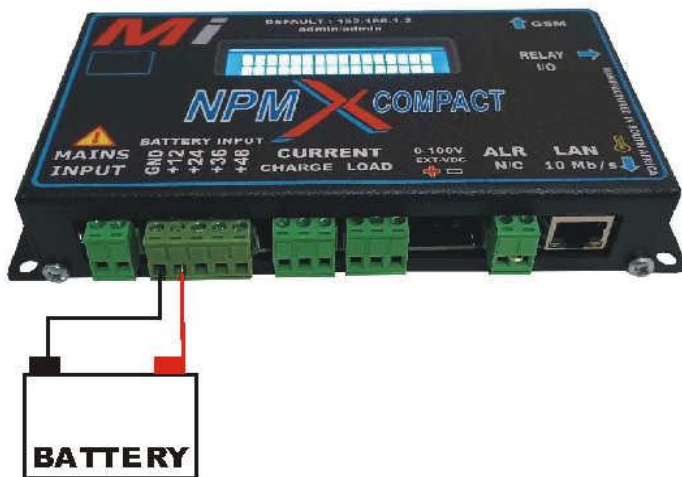

24V example separate Lithium or Lead acid / Gel / AGM

Connect 3 wires from batteries to unit (- from 1st battery to GND, the +12V and +24V terminal

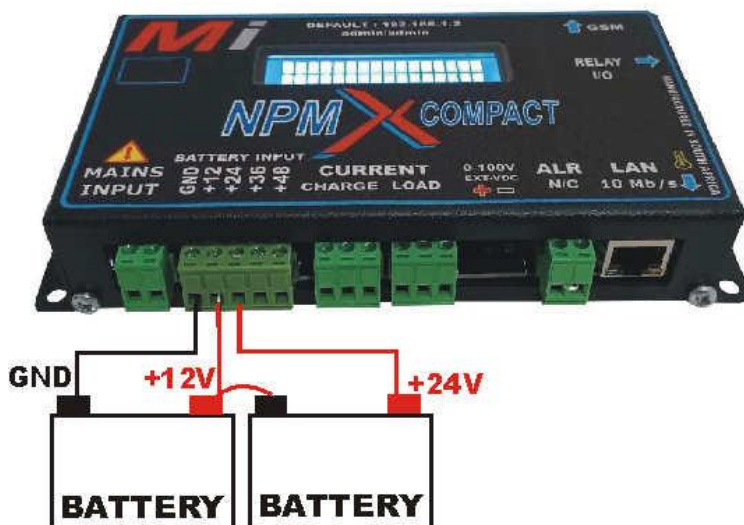

48V example separate Lithium or Lead acid / Gel / AGM

Connect 5 wires from batteries (- from 1st Batt to GND , the +12V ,+24V,+36V and +48V terminal

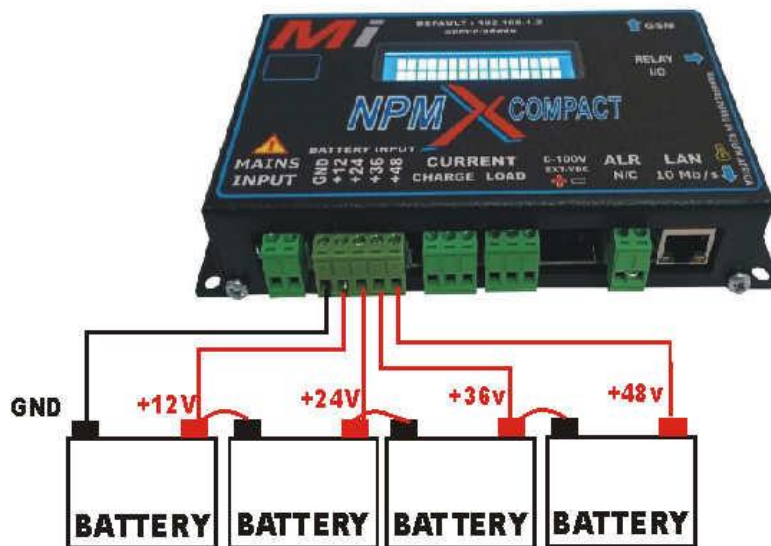

3. BATTERY WIRING FOR LITHIUM BATTERIES

24V Lithium battery example

Connect Battery – to GND terminal and **+24V** from battery to the **+24V** terminal of NPM

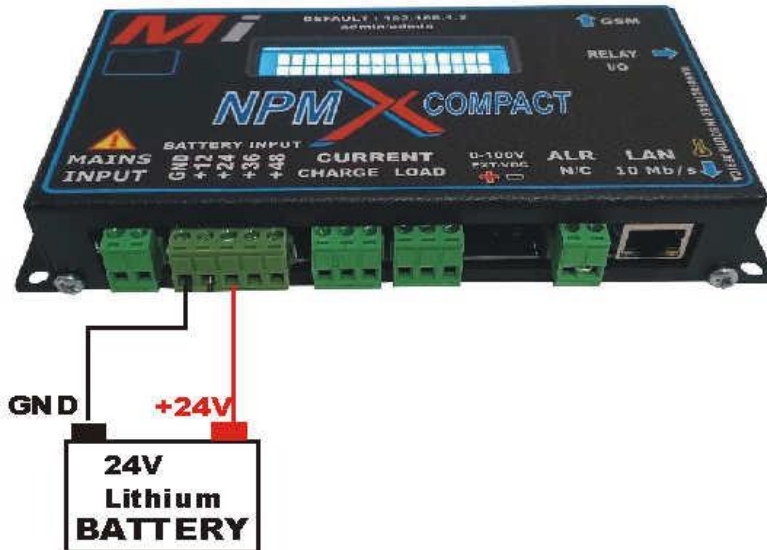

48V Lithium battery example

Connect Battery – to GND terminal and **+48V** from battery to the **+48V** terminal of NPM



4. CURRENT SENSOR CONNECTIONS

CHARGE CURRENT AND LOAD CURRENT SENSORS

4Kv isolated non-contact DC current sensors

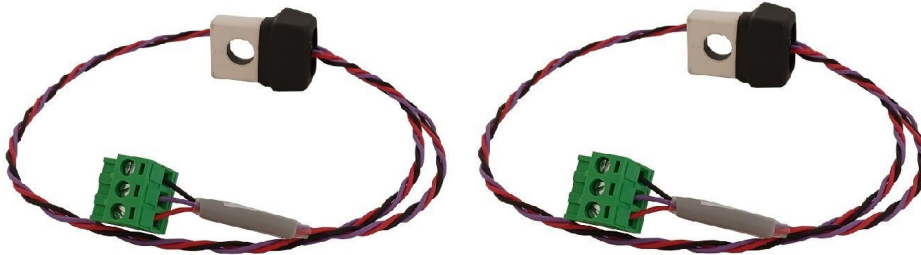

The NPM-X is supplied with **2** pre-calibrated non-contact isolated DC current sensors , the sensors is marked **Charge Sensor** and **Load sensor** -please do not swop around as the sensors is pre calibrated in factory for charge and load current.

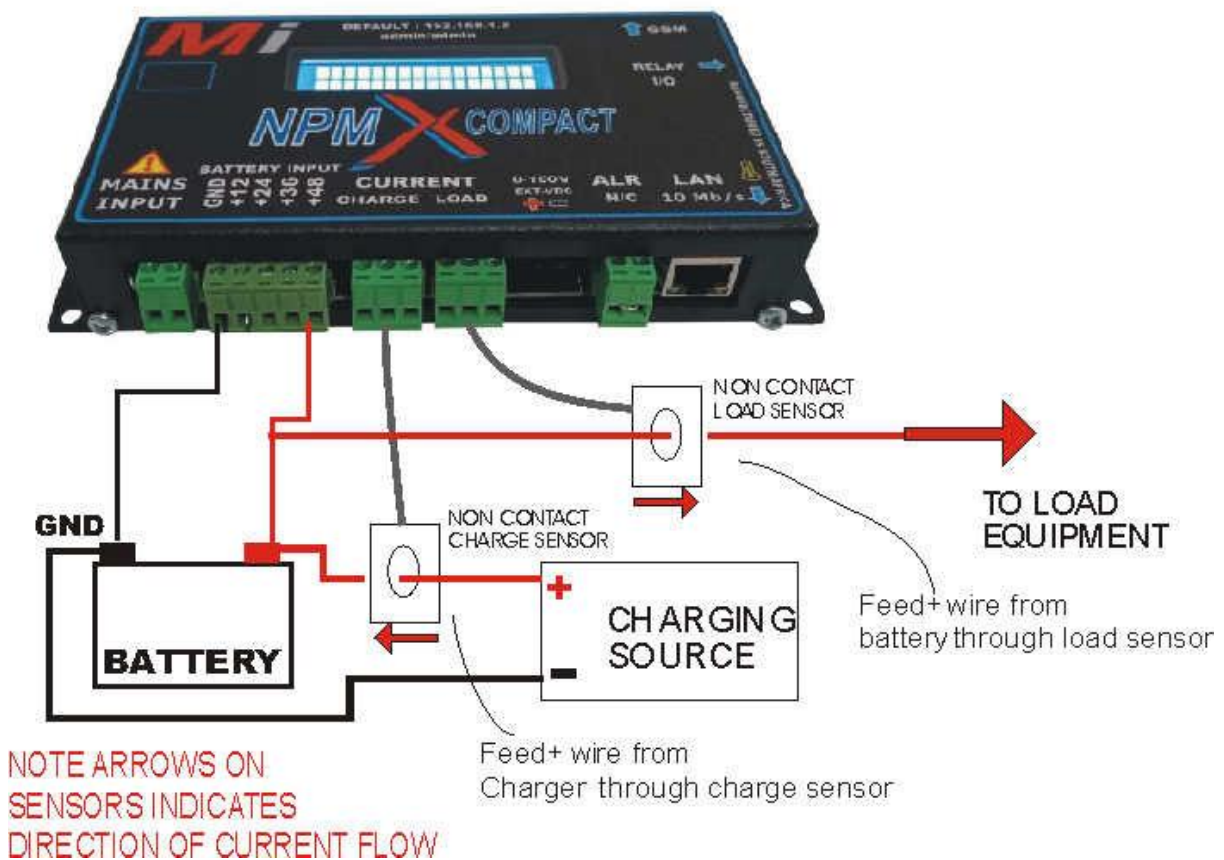

5. ALARM INPUT WIRING



Potential free alarm input

The Alarm input on the NPM is potential free and **NO** voltages should be injected here, this will result in permanent damage.

The user can wire magnetic door switches to the alarm input or the relay output from any type of alarm device to the NPM , beams or passive infra-red detectors as long as the relay output from the device is a dry relay contact.

When the Alarm input is opened (open circuit) the alarm will be triggered and the alarm OID in SNMP will change from 0 to 1 and will stay a 1 for a minimum of 6 minutes even if the alarm input goes closed circuit again.

Because the OID stays a 1 for about 6 minutes , SNMP polling programs wont miss the alarm condition if alarm OID is polled within every 6 minutes.

6. RELAY OUTPUT FUNCTIONS

Relay 1,2,3 can only be toggled individually via the web pages (user password protected) or via **SNMP SET** commands to activate Relay1 ,2 or 3 for 15 seconds to reset external devices which power is connected via the relays.

Relay 4 and 5 can be controlled to the ON or OFF position by the user (user password protected) and will keep the selected position until changed by the user.

The status of all 5 relays is displayed on the home page of the unit by means of yellow dots. The relay is energised when the dot turns yellow.

In the “Relay” control page the user can assign user defined names to each of the relays to help remember what is connected to the relays at the remote site.

All Relay outputs are **potential free** and can switch a maximum of 10 Amps at any voltage from 12Vdc up to 220Vac.

The user should wire the + (positive) supply voltage via the relay to feed the external equipment. Common, normally open and normally closed contacts for each relay are available on the relay connectors to invert the Relay function if needed.

The Relay module connects to the Relay I/O port on the side of the NPM X with a supplied 10 way ribbon cable.



7. OPTIONAL GSM module and functions



The NPM-X **GSM** module interfaces to the NPM-X unit at the rear with a RS232 serial cable.

Setup of GSM module

2 x Cell numbers max. can be added to the NPM-X via the **Network and GSM** setting web page and the cell numbers is stored in the NPM-X and not in the GSM module, this makes administration of the cell numbers easy to change in future by logging into the web page of the NPM-X and simply change the cell number(s).

Insert a SIM card with no pin code request loaded with SMS bundle or a contract sim and connect the GSM module to the NPM-X with the serial cable supplied.

Notice the STATUS led will glow and the NETWORK led will flash at a fast rate
After about 8 sec if the unit finds a Network connection the NETWORK led will start to blink Slowly, wait about 20 sec before sending an SMS

Any alarm from the system will be send via SMS to these configured numbers, when the alarm input goes open circuit and when the AC mains supply fails and restores.*****Only if “Enable SMS send from NPM-RM” is ticked*****

The system will send a **Battery low SMS** if the battery voltage threshold level is reached as configured in the NPM-X web page.

The GSM system software will test for a valid GSM connection every 2 minutes and will auto reboot the GSM module in case the connection was lost to try to re connect the module to a valid GSM network.



SMS Commands

SMS to send	Reply	Action
Help	Returns a list of SMS commands the unit will respond to as below	
Stat or Status	Returns the Status: Mains power status Current battery voltage Charge and load current Relay 4 and 5 status	
Sig	Returns the current GSM signal strength in %	
Balance	Returns the available airtime and SMS available on the SIM card	
Rr1	Reset Relay 1 OK	Toggle relay 1 for time (programmed by user under relay control page)
Rr2	Reset Relay 2 OK	Toggle relay 2 for time (programmed by user under relay control page)
Rr3	Reset Relay 3 OK	Toggle relay 3 for time (programmed by user under relay control page)
R4on	Relay 4 = ON	Switch Relay 4 ON
R4off	Relay 4 = OFF	Switch Relay 4 OFF
R5on	Relay 5 = ON	Switch Relay 5 ON
R5off	Relay 5 = OFF	Switch Relay 5 OFF

8 . DEFAULT IP ADDRESS / RESET AND PASSWORDS



RESET SWITCH

INSERT A BLUNT NON CONDUCTIVE OBJECT INTO THE OPENING, PRESS THE BUTTON. PLUG IN THE BATTERY PLUG, KEEP THE BUTTON PRESSED UNTIL THE LCD INDICATE "RESET COMPLETE" THEN RELEASE BUTTON

Default IP address: 192.168.1.2

PASSWORDS : admin / admin

9. WEB PAGES

Home Page

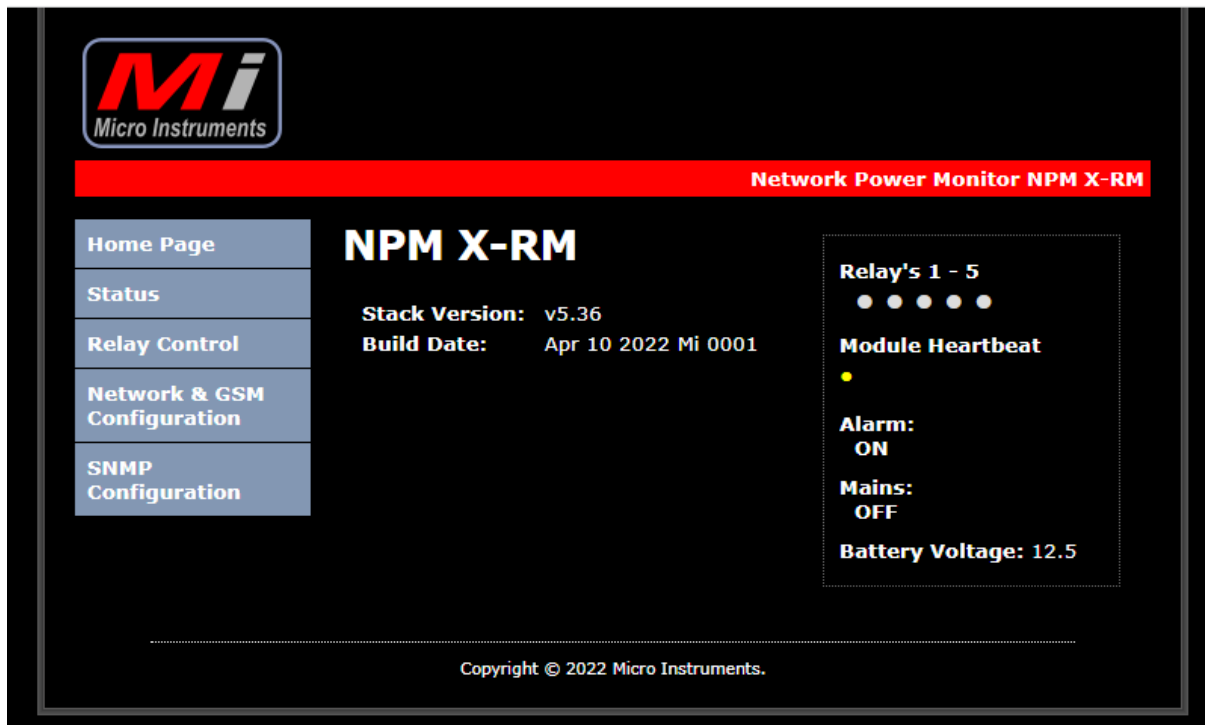

The Stack version is displayed, the build date of the firmware programmed on to the device, the units serial number as well as the model number.

A visual indication of the status of Relays 5 to 1 is given and indicated by a green dot if the relay is active (powered)

A “module heartbeat” indication by a green dot flashes once per second as the software runs through the TCPIP applications.

Alarm – ON/OFF and **Mains** –ON/OFF is displayed

AJAX Browser code for Battery voltage measurements for quick updating of displayed information.

Left hand menu will navigate to different applications on the unit.

STATUS PAGE

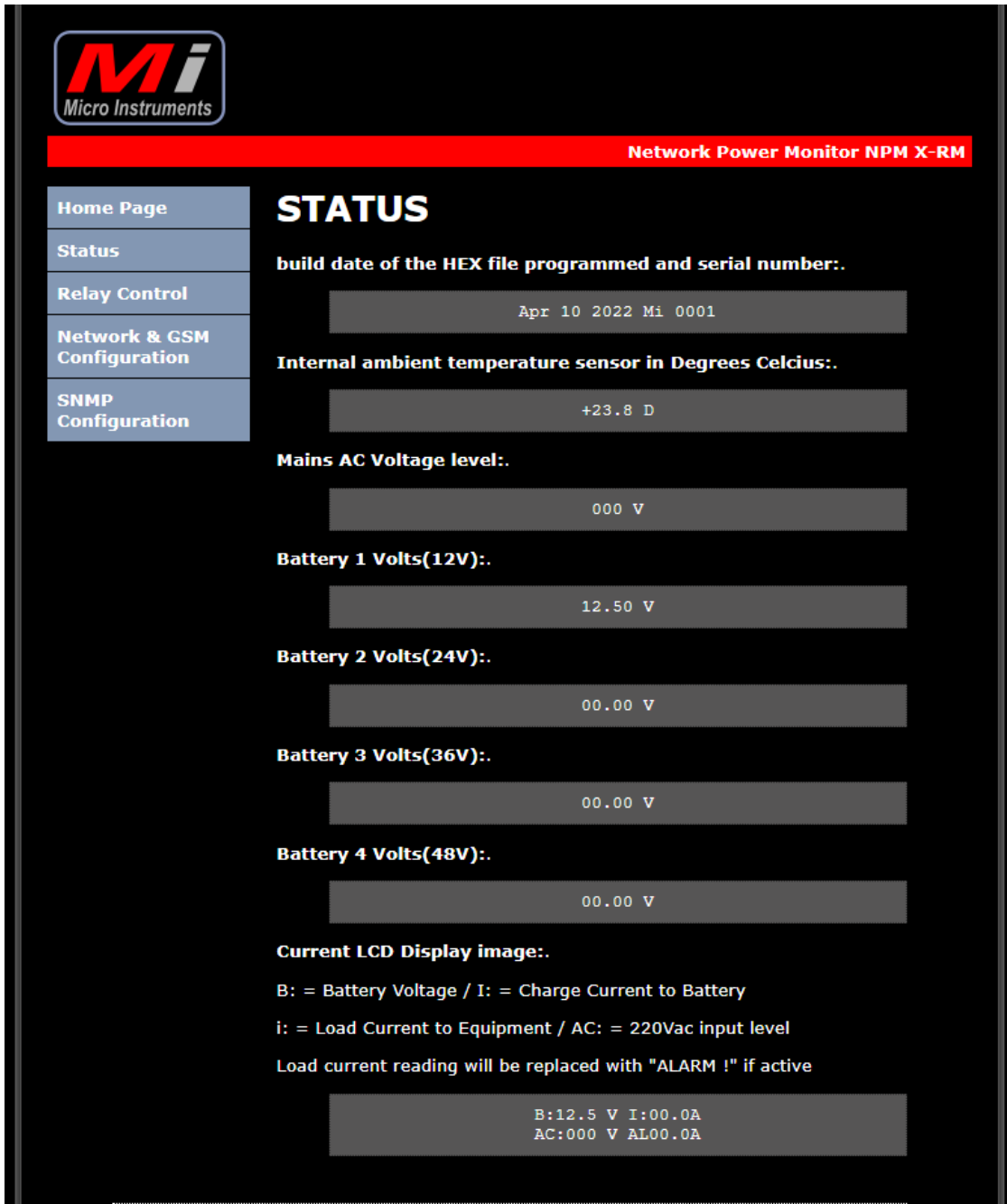

STATUS

build date of the HEX file programmed and serial number:.

Apr 10 2022 Mi 0001

Internal ambient temperature sensor in Degrees Celcius:.

+23.8 D

Mains AC Voltage level:.

000 V

Battery 1 Volts(12V):.

12.50 V

Battery 2 Volts(24V):.

00.00 V

Battery 3 Volts(36V):.

00.00 V

Battery 4 Volts(48V):.

00.00 V

Current LCD Display image:.

B: = Battery Voltage / I: = Charge Current to Battery
i: = Load Current to Equipment / AC: = 220Vac input level
Load current reading will be replaced with "ALARM !" if active

B:12.5 V I:00.0A
AC:000 V AL00.0A

Manufacturing date and serial number is displayed.

Internal temperature sensor is displayed in degrees Celsius.

Mains AC voltage level is displayed

Battery 1 to 4 Voltages is given separately from each other - if all connected

A reflection of the module's LCD display is captured and displayed on this page

Battery voltage, charge current, Mains status on or off and the Load current.

Relay Control page , Network settings page and SNMP config pages is password protected – the user can change the system password under the Network settings page

RELAY CONTROL PAGE

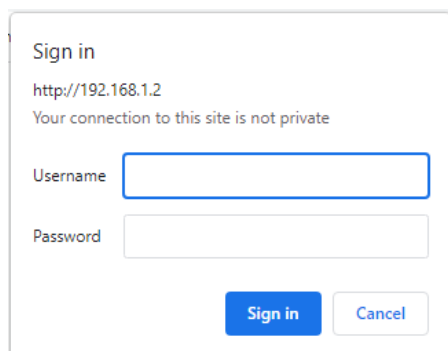

Sign in
http://192.168.1.2
Your connection to this site is not private

Username

Password

Username : admin

Default password : admin

****There is no back door for a lost password – if lost the user will have to factory reset the NPM-X – refer page 9**



Home Page

Status

Relay Control

Network & GSM Configuration

SNMP Configuration

Relay Control Page

This Page application controls the external relay board if present

Relay 1 to 3 / Selecting "Toggle" will activate the specified relay for specified seconds and then return the relay to the off position "

Relay 4 to 5 / Control Relay via on/off command / or SNMP SET command"

Home Page indicate the Relay on/off status"

Relay1 Name(max5):
Relay2 Name(max5):
Relay3 Name(max5):
Relay4 Name(max5):
Relay5 Name(max5):

Save

Relay 4 and 5 can be controlled via (on/off) commands and will keep its position

4: 5:

Send

Relay 1,2,3 can only be toggled and will return to its off position after 15 seconds elapsed

1: 2: 3:

Send

Relay 4 and 5 can be controlled to the on/off status or SNMP "SET" commands and will keep their positions, Relay 1 to 3 can only be toggled for **15 seconds** and is typically used to reset radios or routers without logging yourself out completely from the remote site after a relay was accidentally switched, relay 1 to 3 will return automatically after the 15 seconds to the off position. Names can be assigned to relays to help the user remember what is connected to the relays in the field.

10. Network and GSM Configuration page

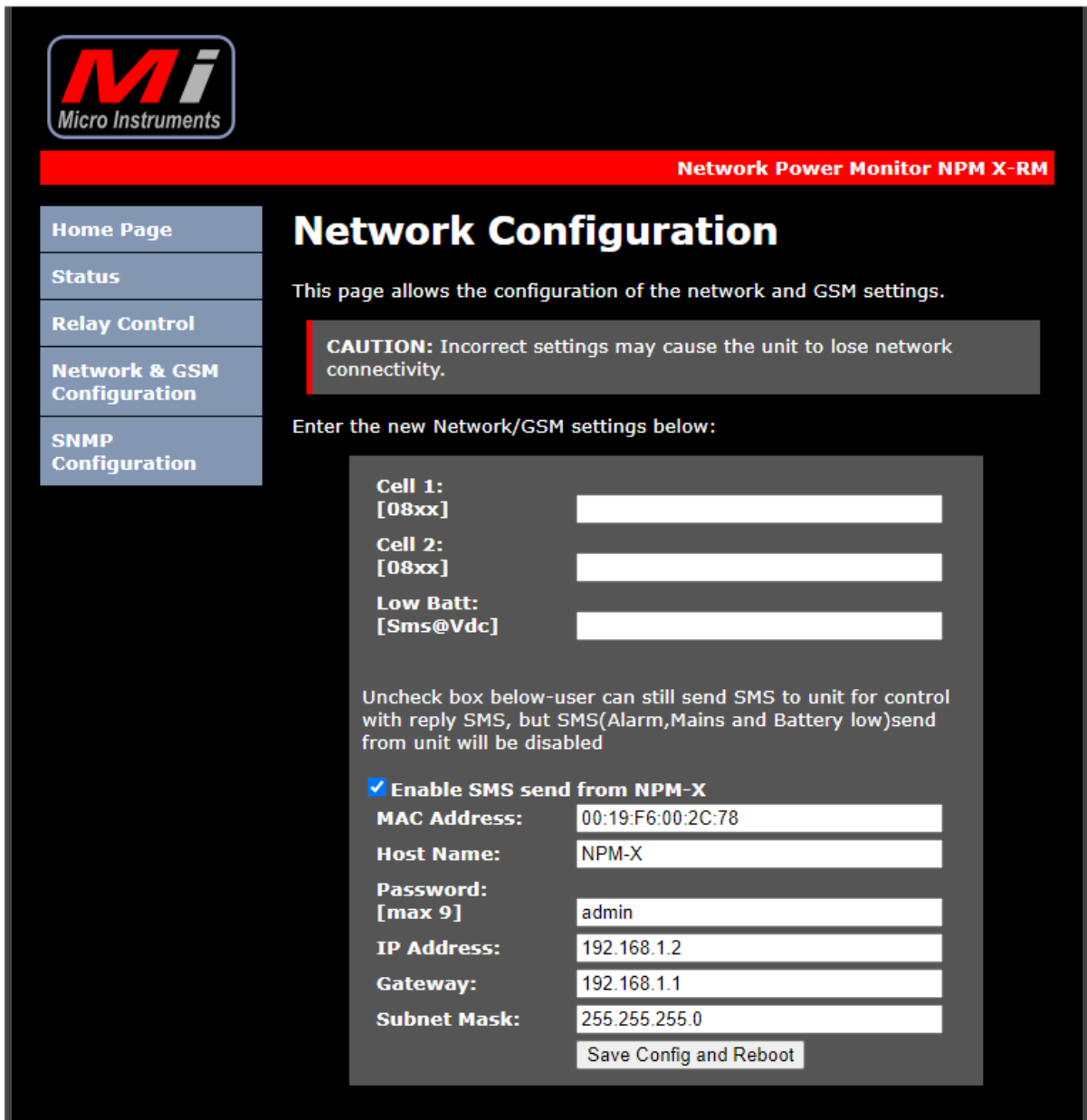

The screenshot shows the 'Network Configuration' page for the Network Power Monitor NPM X-RM. The page features a navigation menu on the left with options: Home Page, Status, Relay Control, Network & GSM Configuration (selected), and SNMP Configuration. The main content area includes a Micro Instruments logo, a title 'Network Configuration', and a description: 'This page allows the configuration of the network and GSM settings.' A caution box states: 'CAUTION: Incorrect settings may cause the unit to lose network connectivity.' Below this, it prompts the user to 'Enter the new Network/GSM settings below:' and provides a form with the following fields: Cell 1: [08xx], Cell 2: [08xx], Low Batt: [Sms@Vdc], a checkbox for 'Enable SMS send from NPM-X' (checked), MAC Address: 00:19:F6:00:2C:78, Host Name: NPM-X, Password: [max 9] admin, IP Address: 192.168.1.2, Gateway: 192.168.1.1, and Subnet Mask: 255.255.255.0. A 'Save Config and Reboot' button is located at the bottom of the form. A note below the form states: 'Uncheck box below-user can still send SMS to unit for control with reply SMS, but SMS(Alarm,Mains and Battery low)send from unit will be disabled'.

User entries

Cell number 1 and 2 if GSM module used

The low battery voltage level for a SMS message

Change Password

The Network settings (IP address , gateway and subnet)

11 . SNMP Configuration

Configure read and write communities

Usually this can be left unaltered

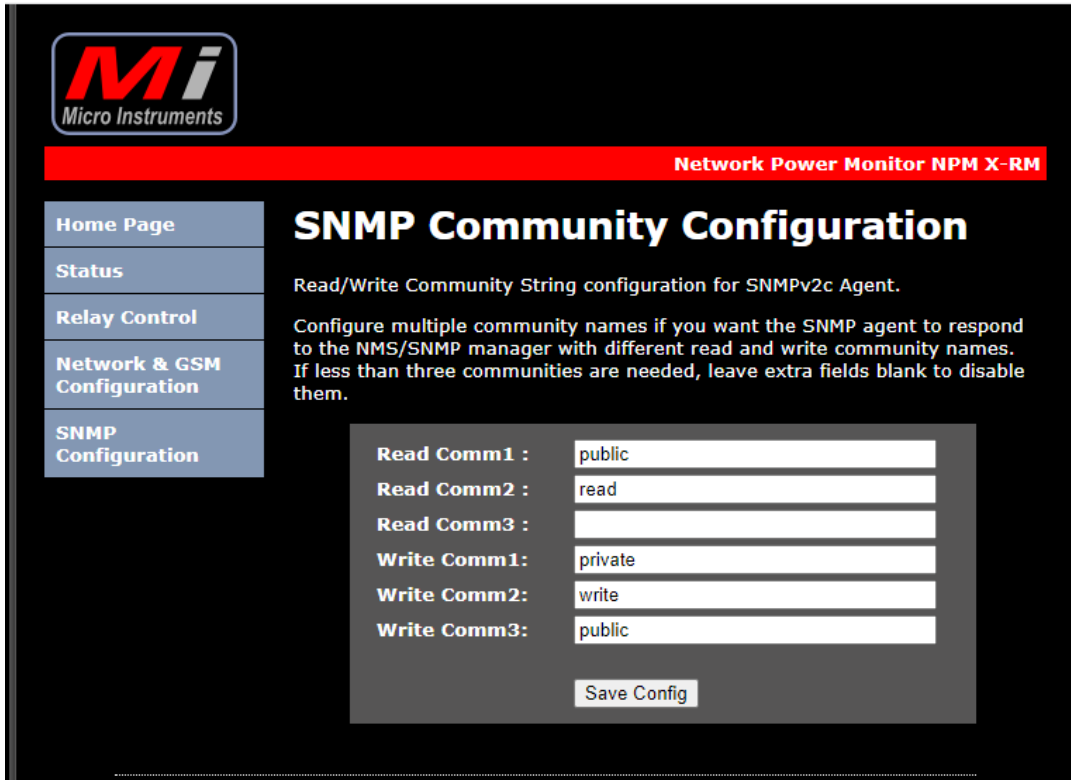

12.TFTP Boot-loader

NPM-X supports **TFTP** Boot-loader for upgrading device software remotely over a network. The MAC address of the unit is hard coded into software for safety reasons so first obtain a .hex file from us for the specific unit before attempting TFTP.

Use TFTP file up-loader downloadable from our website

The user can TFTP to the units current IP address while running or to the private IP address 192.168.97.60 in the first 5 seconds from powering the board.

A TFTP session can also be initiated while the unit is in run mode to the current configured IP address of the unit.

Should the user also have to re-load the webpage files obtained from us

Enter into a web Browser (if default IP address – or enter current IP address of the board) [http://192.168.1.2 /mpfsupload](http://192.168.1.2/mpfsupload)

A window will appear in the browser giving the user the option to browse for the web page files and to upload them to the NPM-RM internal memory.

13. OID Table

1.3.6.1.4.1.45501.1.3.1.0 = Relay 4 status (integer) 0 off / 1 on

1.3.6.1.4.1.45501.1.3.2.0 = Relay 5 status (integer) 0 off/1 on

1.3.6.1.4.1.45501.1.3.3.0 =Mains status (integer) 0 off / 1 on

1.3.6.1.4.1.45501.1.3.4.0 = Total Battery voltage (octet string)

1.3.6.1.4.1.45501.1.3.5.0 = Charge current (octet string)

1.3.6.1.4.1.45501.1.3.6.0 = Load current (octet string)

1.3.6.1.4.1.45501.1.3.7.0 = Mains AC voltage level (octet string)

1.3.6.1.4.1.45501.1.3.8.0 = Temperature (octet string)

1.3.6.1.4.1.45501.1.3.9.0 = Alarm status 0 off / 1 on

1.3.6.1.4.1.45501.1.3.11.0 = Battery 1 (12V) value

1.3.6.1.4.1.45501.1.3.12.0 = Battery 2 (24v) value

1.3.6.1.4.1.45501.1.3.13.0 = Battery 3 (36v) value

1.3.6.1.4.1.45501.1.3.14.0 = Battery 4 (48v) value

14. Mi SNMP MONITOR SOFTWARE

MI SNMP Monitor software for Microsoft Windows

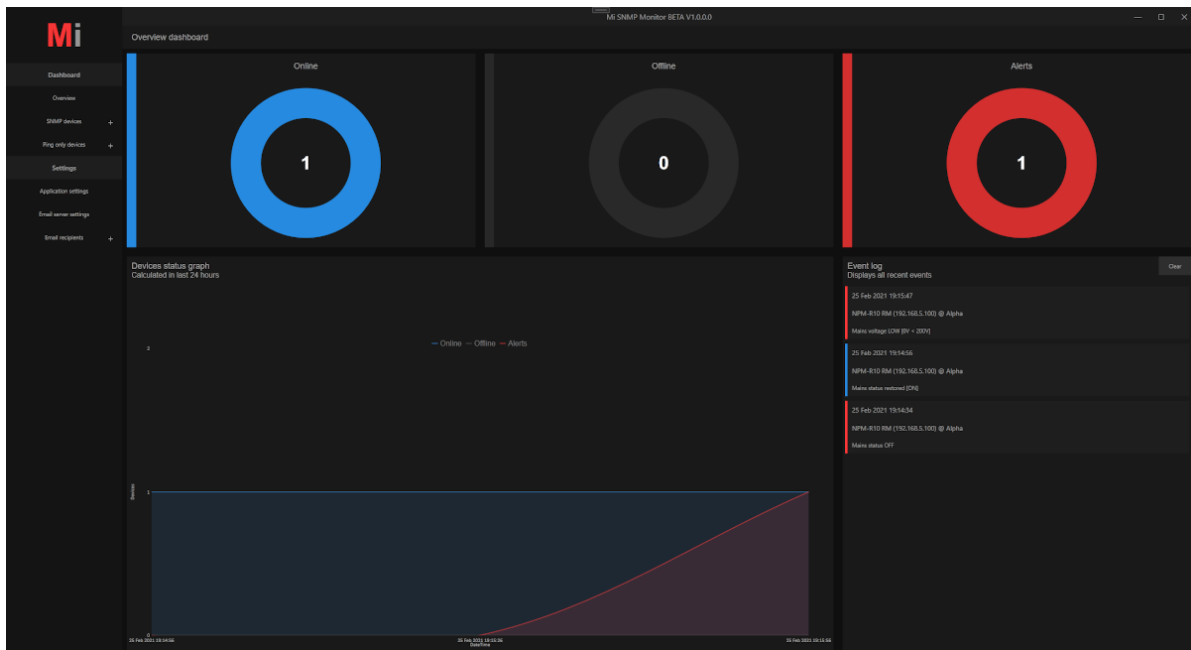

Mi SNMP Monitor is a standalone Microsoft Windows SNMP (simple Network Management Protocol) software application to monitor all Remote power monitoring products manufactured by Micro Instruments. It will also be future compatible with all new products supporting SNMP.

Features:

Plug and Play setup – Quick and easy setup of Mi remote monitoring devices

Can add 3rd party devices to ping the equipment to indicate online / offline status

Graphing – each device added will have its own graphical presentation of all measured data and is unit specific.

Email alerts – Multiple email addresses can be added to the system for all alarm notifications, units going offline and online etc. via email

Email alert can also be converted to **push notifications** to cell phones by using pushover - please visit www.pushover.net

Import and Export – Easily import and export all devices & application settings for easy restore of all information.

Mi SNMP Monitor can be downloaded **FREE** from www.microinstruments.co.za as a fully functional SNMP monitor application for windows. The software package monitors all Mi remote power monitors and also include a ping feature for other devices on the network

15. Physical dimensions

NPM-X Compact

(L) = 185mm

(H) = 35mm

(W) = 85mm

Weight = 0.5 kg

RS232- GSM Module

